

产品型号: BW12

日期: 2018.8.23

版本: V1.0

# 承认书

客户名称: \_\_\_\_\_

型号:         BW12        

博安通物料编码: \_\_\_\_\_

规格描述.:         SINGLE-CHIP 802.11b/g/n 1T1R WLAN SoC Module        

出厂签章:

编写	审核	批准
关宁	杨小飞	徐付强

客户承认签章:

检查	审核	批准

博安通联系方式:

公司地址: 深圳 OFFICE: 深圳市宝安区 67 区留芳路凌云大厦研发楼 10 楼 中山工厂地址: 中山市南朗镇东方工业园 A 栋 电话: 0760-88580932 传真: 0760-89961414 网站: <a href="http://www.tech-now.com">http://www.tech-now.com</a>		
业务联系人:	手机:	邮箱:
技术联系人:	手机:	邮箱:
品质联系人:	手机:	邮箱:

# 说明书

## SINGLE-CHIP 802.11b/g/n 1T1R WLAN SoC Module

**BW12**

版本: V1.0

### 文件制定/修订/废止履历表

版本	日期	制定/修订内容	制定	核准
<b>V1.0</b>	2018.8.23	首次制定	关宁	杨小飞

# 1. 概述

BW12 是一款高集成度的 WIFI SOC 模组。主芯片 RTL8710BX 是一款低功耗芯片，它内置了 1 颗 ARM-CM4F 的 MCU，集成了 WLAN、MAC、1T1R 支持的 WLAN 基带和 RF 基带,且提供了一组可配置的 GPIO 口，用于不同外围设备的控制。

BW12 内置功能齐全的王IFI 协议，嵌入式的内存还配备简单的应用程序开发。

# 2. 特性参数

## 概要

- 封装 SMT-16 PIN (24mmx16mm)
- 芯片集成 CMOS MAC、射频和 PHY 基带，兼容 WLAN 的 802.11b/g/n 协议。
- 配备 802.11n 的 2.4GHz 解决方案
- 兼容 802.11n 规范

## 支持标准协议

- 802.11b/g/n compatible WLAN
- 802.11e QoS Enhancement (WMM)
- 802.11i (WPA, WPA2). Open, shared key, and pair-wise key authentication services
- WIFI WPS support
- WIFI Direct support
- Light Weight TCP/IP protocol

## WLAN 物理特性

- 802.11n OFDM
- 一发一收路径 (1T1R)
- 20MHz 传输带宽
- 保护间隔短 (400ns)
- DSSS 、 DBPSK 、 DQPSK、 CCK 采用短序和长序调制方式。
- 具有 BPSK、QPSK、16QAM 和 64QAM 调制的 OFDM，卷积编码速率:1/2、2/3、3/4 和 5/6
- 最大数据速率为 54Mbps (802.11g)和 72.2Mbps (802.11n)

## 外围接口

- 1 个 URAT 接口
- 1 个支持标准波特率 UART 接口
- 2 个 I2C 接口和 UART 接口共享
- 1 个 SPI 接口和 UART 接口共享
- 1 个 SPI 接口支持 10.4MHz 波特率。
- 5 个 PWM 接口
- 1 个 SWD 接口
- 以上接口都可以作为 GPIO 使用

## 3. 应用

- M2M
- 射频识别
- 传感器

## 4. 总体规范

型号	BW12
产品类型	SoC WIFI module
主要芯片	RTL8710BX
支持协议	802.11 b/g/n
通信接口	UART,I2C,SPI,GPIO,SWD,PWM
标准电压	3.3±10% V
工作温度	-20 ~ +85° C ambient temperature
存储温度	-40 ~ 125°C ambient temperature
工作湿度	5 to 93 % maximum (non-condensing)
封装尺寸	24 x16x 3mm (LxWxH) ±0.2mm

## 5. 框图

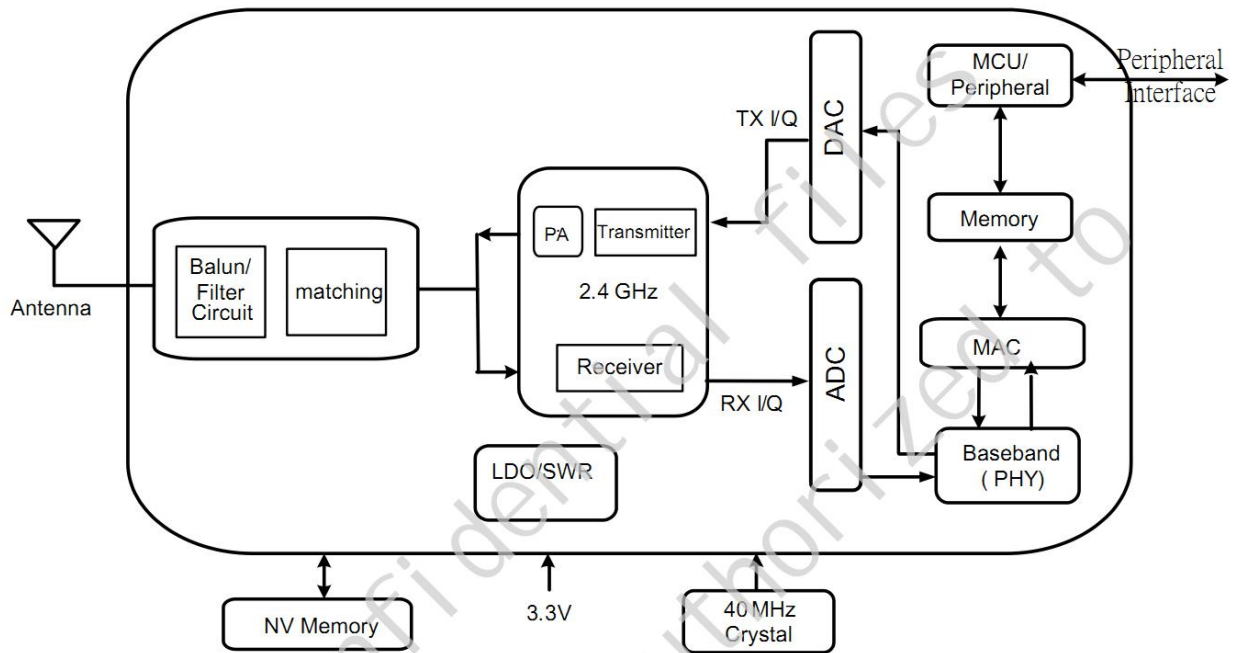

Figure 7 Single-Band 11n (1x1) Solution

## 6. 电气特性

### 1) DC Characteristics (直流特性)

Current Consumption	Min.	Typ.	Max.	Unit
DC 3.3V	-	50	300	mA

### 2) RF Characteristics for IEEE802.11b (802.11b 的 RF 特性)

Items	Contents			
Specification	IEEE802.11b			
Mode	CCK 11 Mbps			
Channel frequency	2412 ~ 2484 MHz			
Freq.Error( $\pm 15$ ppm)	$\pm 10$ ppm			
RX (PER $\leq -76$ dBm@8%)	-85 dBm			
TX Characteristics	Min.	Typ.	Max.	Unit
Power Level ( dBm)		18		dBm
EVM ( $\leq -9$ dB)		-22		dB

### 3) RF Characteristics for IEEE802.11g (802.11g 的 RF 特性)

Items	Contents			
Specification	IEEE802.11g			
Mode	OFDM 54Mbps			
Channel frequency	2412 ~ 2484 MHz			
Freq.Error( $\pm 15$ ppm)	$\pm 10$ ppm			
RX (PER $\leq -65$ dBm@10%)	-73 dBm			
TX Characteristics	Min.	Typ.	Max.	Unit
Power Level ( dBm)		16		dBm
EVM ( $\leq -25$ )		-30		dB

### 4) RF Characteristics for IEEE802.11n (BW20\_MCS7)

(802.11n 的 RF 特性)

Items	Contents			
Specification	IEEE802.11n BW20_MCS7			
Mode	BW20_MCS7 65 Mbps			
Channel frequency	2412 ~ 2484 MHz			
Freq.Error( $\pm 15$ ppm)	$\pm 10$ ppm			

RX (PER≤-64dBm@10%)	-72 dBm			
TX Characteristics	Min.	Typ.	Max.	Unit
Power Level ( dBm)		15		dBm
EVM (≤-28)		-30		dB

## 7. 封装尺寸和引脚定义

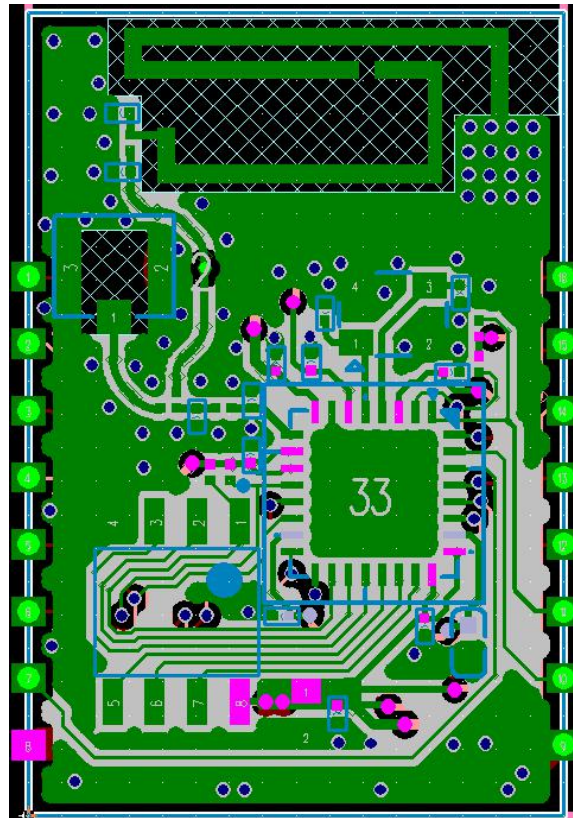



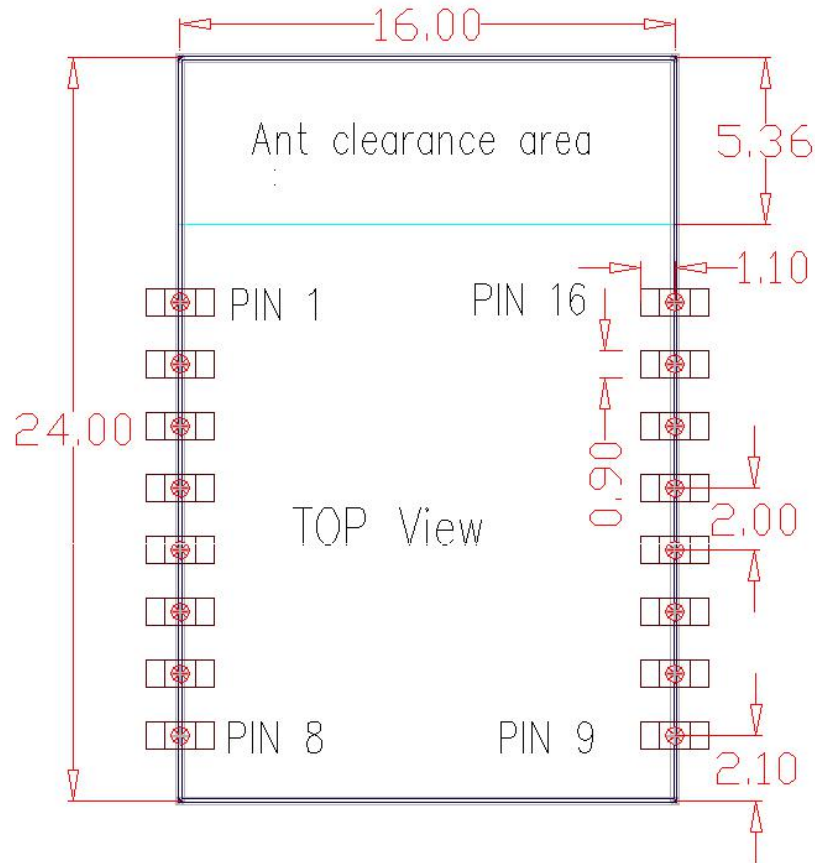

Fig. Module front view

引脚号	定义	I/O口	描述
1	GPIOA_15	IO	GPIO pin. The MUX function can be referred to Pin Function Table
2	VBAT_MEAS	NA	Reserved
3	CHIP_EN	I	Enable chip. 1: enable chip; 0: shutdown chip
4	GPIOA_5	IO	GPIO pin. The MUX function can be referred to Pin Function Table
5	GPIOA_29	IO	GPIO pin. The MUX function can be referred to Pin Function Table
6	GPIOA_0	IO	GPIO pin. The MUX function can be referred to Pin Function Table
7	GPIOA_19	IO	GPIO pin. The MUX function can be referred to Pin Function Table
8	VDD33	Power	3.3V INPUT,300mA MAX
9	GND	GND	GND
10	GPIOA_22	IO	GPIO pin. The MUX function can be referred to Pin Function Table
11	GPIOA_30	IO	GPIO pin. The MUX function can be referred to Pin Function Table

12	GPIOA_14	IO	GPIO pin. The MUX function can be referred to Pin Function Table
13	GPIOA_12	IO	GPIO pin. The MUX function can be referred to Pin Function Table
14	GPIOA_15	IO	GPIO pin. The MUX function can be referred to Pin Function Table
15	GPIOA_18	IO	GPIO pin. The MUX function can be referred to Pin Function Table
16	GPIOA_23	IO	GPIO pin. The MUX function can be referred to Pin Function Table

IO 口功能总表

PIN name	UART	SPI Master	SPI Slave	SPI Flash	I2C	SDIO	PWM/TIMER	EXT32K	I2S	Others
GPIOA_14							PWM0	SWD_CLK		
GPIOA_15							PWM1	SWD_DATA		
GPIOA_0							PWM2	ext_32k		
GPIOA_12							PWM3			
GPIOA_6				SPIC_CS		SD_D2				
GPIOA_7				SPIC_DATA1		SD_D3				
GPIOA_8				SPIC_DATA2		SD_CMD				
GPIOA_9				SPIC_DATA0		SD_CLK				
GPIOA_10				SPIC_CLK		SD_D0				
GPIOA_11				SPIC_DATA3		SD_D1				
GPIOA_5						SDIO_SIO_DEBAND_INT	PWM4			WAKEUP_1
GPIOA_18	UART0_RXD	SPI1_CLK	SPI0_SCK		I2C1_SCL	SD_D2	TIEMER4_TRIG		I2S_MCK	WAKEUP_0
GPIOA_19	UART0_CTS	SPI1_CS	SPI0_CS		I2C0_SDA	SD_D3	TIEMER5_TRIG		I2S_SD_TX	ADC1
GPIOA_2	UART0_RTS	SPI1_MISO	SPI0_MISO		I2C0_SCL	SD_D0	PWM5		I2S_WS	WAKEUP_2
GPIOA_23	UART0_	SPI1_MOSI	SPI0_MOSI		I2C0_SDA	SD_D1	PWM0			WAKEUP_3

3	TXD	SI	OSI							
GPIOA_3 0	UART2_I og_TX				I2C0_SDA		PWM3	RTC_OUT		
GPIOA_2 9	UART2_I og_RX				I2C0_SCL		PWM4			